

PRELIMINARY: XTRX-2x2 Software Defined Radar

XTRX-2x2 is a programmable Software Defined Radar (SDR) in the X-band for various applications like drone or bird tracking, perimeter intrusion detection, and scientific purposes. Chirp bandwidths up to 80 MHz and the capability for generating arbitrary chirps enable maximum versatility for your application.

Product Description

Based on our embedded SDR platform, XTRX-2x2 is a simple, yet powerful standalone software-defined radar. It is designed to provide maximum versatility for your cognitive radar implementations. FPGA-based DSP algorithms enable future implementations for varying use-cases.

Radar data post-processing may be performed by a co-processor on the SDR itself, with enough power for most customer-specific applications. Alternatively, data streaming to a post-processor is supported out-of-the-box.

We selected a well-established and open-source driven API called "liblIO" for data streaming and radar parameter configuration. liblIO is widely used and supported out-of-the-box by the most popular signal processing software.

A signal generator in the FPGA is capable of generating FMCW chirps or arbitrary signals such as noise and non-linear modulated chirp signals with up to 80 MHz bandwidth. TX waveforms are loadable from the Linux user space.

Received echo signals are processed with a double-heterodyne receiver optimized for maximum dynamic range, high selectivity and excellent receiver noise figure.



Our compact, fully integrated SDR module: Ethernet interface, low power consumption in a robust, shielded casing are just some of the features we offer.

Benefits & Highlights of our Solution

- ▶ 2 Tx / 2 Rx antennas
- ▶ Channel coherent signal processing
- ▶ Rx direction of arrival estimation
- ▶ Dual chirp generator
- ▶ System-on-chip with FPGA and ARM processors
- ▶ Co-processors for range doppler processing
- ▶ Free DSP resources for future extensions
- ▶ Onboard Linux allows standalone applications
- ▶ Open-source API for data streaming and control
- ▶ Three-stage ultra-low phase noise clock generator with OCXO and GPS as reference
- ▶ Multi-device synchronization with GPS
- ▶ All-in-one hardware solution

Functional Diagram

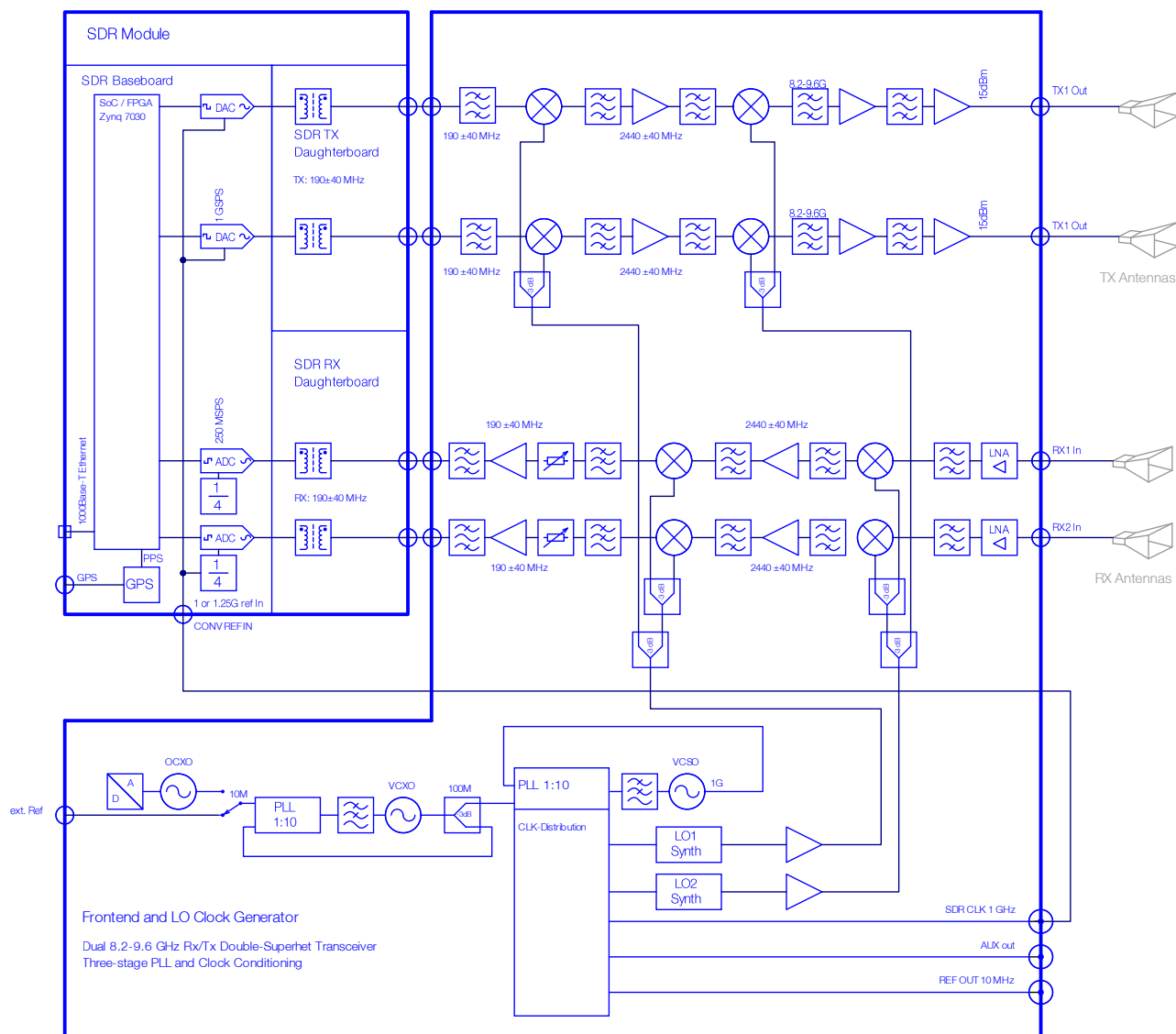

TRX-2x2 is partitioned in two functional modules:

Module "Frontend and LO Clock Generator" contains the LO and clock generation subsystem, implemented as a three-stage PLL with clock distribution and synthesizers for the LO mixer signals.

Beneath the LO and clock subsystem, the overall analog X-band frontend is located in the same module. It is

implemented as a dual super-heterodyne transceiver.

Module "SDR" contains all analog converters, FPGA signal processing, housekeeping and supervision, 1000BASE-T Ethernet, GPS and any other interfaces to the outside world.

Grey parts are not part of the datasheet.

Radar Key Specification

Parameter	Value	Unit
Number of RF channels	2 Tx, 2 Rx	
RF frequency range*	8.2-9.6	GHz
Tx output power	15	dBm max.
Chirp bandwidth	80	MHz
A/D converter sampling rate	250	MSPS
A/D converter resolution	14	Bit
D/A converter sampling rate	1000	MSPS
D/A converter resolution	16	Bit
AUX CLK outputs	0.1-1	GHz
RF/CLK port impedance	50	Ω
RF port reflections (S11)	-10	dB max.
Supply voltage	10-15	V DC
Power consumption	60	W max.
Streaming interface	1000BASE-T	Ethernet
Streaming protocol	libiio	

* Frequency range can be adapted to any passband between 5-12 GHz with 1.4 GHz max. bandwidth.

Radar Instrumentational Performance

The following radar parameters depend on the radar configuration.

Parameter	Value	Unit
Chirp length	235.93	μ s
Pulse repetition frequency	4.2386	kHz
Chirp deviation	593.4	GHz/s
Frequency resolution per meter	3.959	kHz/m
Range resolution per bin	1.205	m/bin
Instrumentation range	1110	m max.
Doppler speed	33.65	m/s max.

Typical Electrical Performance Data

Measurement conditions unless otherwise noted:

$$f_{RFin} = 9.44 \text{ GHz}, f_{IF} = 190 \text{ MHz}$$

Values defined in a range are depending on Rx gain settings.

Parameter	Condition	Value	Unit
Rx input intercept point (IIP3)		2.9	dBm
Rx noise figure		11.8	dB
Rx input power		-34.5...-6	dBm max.
Rx relative noise spectrum density		-144...-132	dBFS/Hz
Rx effective noise spectrum density		-162...-139	dBm/Hz
Rx spurious free dynamic range	$P_{in} = -50 \text{ dBm}$ $f_{if} = 5...1000 \text{ MHz}$	70	dBc min.
Tx Phase Noise	$f_{Offset} = 10 \text{ Hz}$	-66.3	dBc/Hz
	$f_{Offset} = 100 \text{ Hz}$	-82.1	dBc/Hz
	$f_{Offset} = 1 \text{ kHz}$	-95.6	dBc/Hz
	$f_{Offset} = 10 \text{ kHz}$	-103.3	dBc/Hz
	$f_{Offset} = 100 \text{ kHz}$	-102.3	dBc/Hz
	$f_{Offset} = 1 \text{ MHz}$	-122.1	dBc/Hz
	$f_{Offset} = 10 \text{ MHz}$	-141.6	dBc/Hz
Tx RMS Jitter	$f_{Offset} = 0.012\text{-}20 \text{ MHz}$	86.7	fs

Not finding what you want to know? Don't hesitate to ask our experts for further details.

Mechanical Form Factors

XTRX-2x2 is delivered in a 19" rack-mountable chassis including an AC power supply, fuses, and cooling fans.

Internally, each module housing is milled from bare-Aluminum to guarantee optimal heat transfer and RF shielding.

Not fitting to your needs? XTRX-2x2 can also be delivered in other form factors or as bare modules. Please contact us for custom solutions.



19" rack version as all-in-one solution: X-band radar, PSU, fuse and thermal management



A transportable, ruggedized case is available: it perfectly fits your next field study



Modular version ready for integration in other systems

Your personal contact:
Andreas Zutter
zutter@precisionwave.com
+41 32 513 57 52